

Fan Coil Preventative Maintenance

What is a Fan Coil?

Fan coil units (FCUs) are a type of HVAC system commonly found in high-rise condominiums. The fan draws ambient air from the suite across a coil containing hot or cold liquid. The air is heated or cooled depending on the season and thermostat settings, and then recirculated into the suite. A fan coil does more than heat and cool, it also cycles and filters the air in your home.



Fan Coil Preventative Maintenance Scope of Work

As a follow-up to recent inspections, Unilux is offering a bulk discounted preventative maintenance package to residents of 77 E. Walton.

Scope of Work including but not limited to:

- HEPA vacuum entire cabinet, including insulation, walls, coil, drain pan, blower, and access door
- Remove debris from drain pan and drain line to ensure they're clear and in full operation
- Check fan parts for wear and tear
- Change the customer-provided air filter
- Check and tighten electrical connections
- Provide a detailed report of findings including photos

Total Cost: \$150 per fan coil for vertical and horizontal fan coil units

Typical Vertical Fan Coil

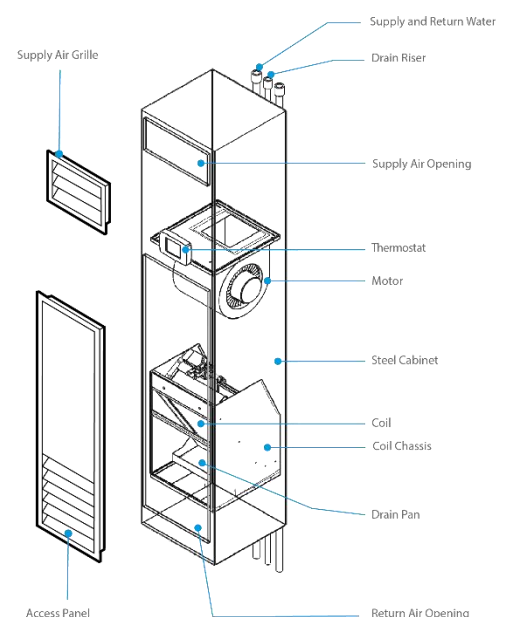

To Proceed

Please pay online by visiting <http://uniluxpayments.com/residencesat900>

Timing of Work

To optimize scheduling and labor efficiency to pass the savings on to you, Unilux will perform all the maintenance together (as opposed to individual trips to your building). The work in your building will begin on Monday, June 24. Unilux will coordinate with building management to notify residents of the schedule and corresponding entry of a technician into your home.

Thank you and please do not hesitate to call us should you have any questions.

Typical Horizontal Fan Coil

